

TENSITRON®



Operating Instructions ACX-1 Series Digital Aircraft Cable Tension Meter



TABLE OF CONTENTS

1.	WARRANTY POLICY	4
2.	SPECIFICATIONS	5
3.	SAFETY AND MAINTENANCE	6
4.	INSTRUMENT OPTIONS	7
	STANDARD INSTRUMENTS	7
	ADD-ON OPTIONS	8
	<i>Analog Output Option</i>	8
	<i>RS-232 Serial Output Option</i>	8
	FEATURES OF ALL INSTRUMENTS	8
5.	BASIC OPERATION	9
	CHARGING INSTRUMENT BATTERIES.....	9
	QUICK START INSTRUCTIONS	9
	ENGAGING INSTRUMENT ONTO CABLE	11
6.	DISPLAY SCREENS	13
	SETUP SCREEN	13
	<i>LCD Refresh Rate</i>	13
	<i>Data Averaging</i>	13
	<i>Custom Names</i>	13
	<i>Re-Calibrate Tension</i>	13
	<i>Audio</i>	13
	<i>Backlight</i>	14
	<i>Set-Point Menu</i>	14
	<i>Version</i>	14
	DATA LOGGING SCREEN	14
	<i>View Data Stats</i>	14
	<i>View Data Log</i>	15
	<i>Clear Single Point Log</i>	15
	TENSION UNITS SCREEN	15
	SELECT MATERIAL SCREEN	15
7.	ADVANCED OPERATION	16
	GENERAL CALIBRATION PRECAUTIONS.....	16
	CHECK ACCURACY	16
	CALIBRATE INSTRUMENT.....	17



Proprietary Notice

This document contains proprietary information which may not be reproduced in whole or in part without the written permission of Tensitron, 733 South Bowen Street, Longmont, CO 80501.

Tensitron reserves the right to make instrument changes and improvements which may not be reflected in this document. Portions of this document may have been updated to include the latest hardware or firmware version, if applicable. We recommend that this document be read in its entirety before any attempt is made to operate the instrument.

Thank You . . .

For purchasing another fine product from Tensitron

If you have any questions or need assistance, please call us at 303-702-1980 or find us online at www.tensitron.com



STANDARD EQUIPMENT WARRANTY

Tensitron warrants that all Tensitron-manufactured equipment will be free of any defect in materials or workmanship for the period of (1) year. Warranty begins from the date of shipment from a Tensitron facility. The warranty is extended to customers and applies to all Tensitron-manufactured equipment purchased, installed, and used for the purpose for which such equipment was originally designed. The above warranties cover only defects arising under normal use and do not include malfunctions or failures resulting from misuse, abuse, neglect, alteration, problems with electrical power, usage not in accordance with product instructions, acts of nature, or improper installation or repairs made by anyone other than Tensitron. Tensitron reserves the right in its sole discretion to determine warranty coverage. Shipping costs to and from Tensitron are not included in the warranty coverage.



FULL SCALE ACCURACY

For all models up through 500 lb.: **2%**
 For ACX-1200-1: **3%**

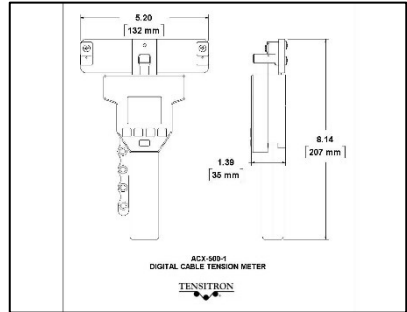
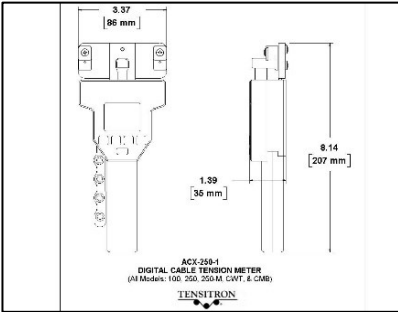

Figure 1: ACX-1 Dimensions

Accuracy for custom calibrations is material specific

Power Requirements

For Instrument Input: 9 VDC...2.2A
 For AC Adapter: 100-240V~50-60Hz 0.48A
 Battery: Rechargeable NiMH, custom proprietary design
 Power Supply operates with input voltages from 100 – 240V and includes several interchangeable adapters allowing use with European, U.S., Australian, English and other plug configurations.

Battery Life

Approximately 8 hours depending upon backlighting intensity.

Dimensions

All models except 500 and 1200: 3.37" x 8.14" x 1.39"
 ACX-500 and 1200: 5.20" x 8.14" x 1.39" (See Figure 1)

Weight

1.5 lb. (depending upon instrument configuration).

Environment

Indoor or outdoor use, dust-free environment.



WARNING: When using cordless, electronic instruments, always follow basic safety precautions to reduce the risk of fire, electric shock and personal injury



USE ONLY A TENSITRON POWER SUPPLY TO AVOID DAMAGE TO INSTRUMENT.



READ AND SAVE ALL INSTRUCTIONS FOR FUTURE USE. Before use, ensure all users read and understand this manual, as well as any labels packaged with or attached to the instrument.

- Know your instrument. Read this manual carefully to learn your tension meter's applications and limitations, as well as the potential hazards associated with this type of instrument.
- Avoid dangerous environments. Do not use your instrument in the presence of explosive atmospheres (gaseous fumes, dust or flammable materials). Do not submerge your instrument in liquids.
- Use the right tool or instrument. Do not use this instrument to do a job for which it is not recommended.
- Check for damaged parts. Inspect instrument before use. Check for any binding of moving parts, improper mountings, broken parts and any other condition that may affect operation. Do not use a damaged instrument. Tag damaged instrument "DO NOT USE" until repaired. For repair, send instruments directly to Tensitron.
- Guard against electric shock.
- Maintain instrument carefully. Protect meter from exposure to water. Keep instrument dry, clean, and free from oil and grease. Do not lubricate. All roller bearings are sealed.
- Do not use instrument if it has received a sharp blow, been dropped or damaged in any way. Do not disassemble. Incorrect reassembly may result in damage to the instrument and risk of electric shock and fire. If instrument is damaged return it to Tensitron for repair.
- Unplug charger when not in use.
- **WARNING:** Only use battery pack assemblies provided by Tensitron with your meter (P/N: BATTERY, ACX). Other types of batteries might explode, causing personal injury and damage.
- To check this meter's accuracy, see "Check Accuracy" on page 13. If meter is out of calibration, return it to Tensitron for repair.
- Tensitron recommends calibration by the manufacturer at one-year intervals, or sooner if the meter is worn, damaged, or reading incorrectly. However, it is the responsibility of the user to establish a suitable calibration interval, considering such factors as the user's accuracy requirements, requirements set by contract or regulation, and environmental factors such as frequency and conditions of the meter's use.



STANDARD INSTRUMENTS

Model	Cable Selection	Resolution (pounds)	Range (pounds)
ACX-25-1	1/16, 3/32"	0.2	0.5-25
ACX-25-M-1	2.0, 2.5mm	0.2	0.5-25
ACX-25-FM-1	1/16, 3/32", 2.0, 2.5mm	0.2	0.5-25
ACX-100-1	1/16", 3/32", 1/8", 5/32"	0.2	1-100
ACX-100-M-1	2.0mm, 2.5mm, 3.5mm	0.2	1-100
ACX-100-FM-1	1/16", 3/32", 1/8", 5/32", 2.0mm, 2.5mm, 3.5mm	0.2	1-100
ACX-100-CMB-1	1/16, 3/32, 1/8, 5/32", 5, 10, 15, 20, 25 CWT	0.2	1-100
ACX-250-1	1/16", 3/32", 1/8", 5/32", 3/16"	0.2	1-250
ACX-250-M-1	2.0mm, 2.5mm, 3.5mm, 4.0mm	0.2	1-250
ACX-250-FM-1	1/16", 3/32", 1/8", 5/32", 3/16", 2.0mm, 2.5mm, 3.5mm, 4.0mm	0.2	1-250
ACX-250-CWT-1	5, 10, 15, 20 & 25 CWT cables	0.2	1-250
ACX-250-CMB-1	1/16", 3/32", 1/8", 5/32", 3/16", 5, 10, 15, 20, 25 CWT	0.2	1-250
ACX-500-1	3/32", 1/8", 5/32", 3/16". 1/4"	1	1-500
ACX-500-M-1	2.5, 3.5, 4.0, 4.5mm	1	1-500
ACX-500-FM-1	3/32", 1/8", 5/32", 3/16", 1/4", 2.5, 3.5, 4.0, 4.5mm	1	1-500
ACX-1200-SCB-1	3/16"	5	50-1200



ADD-ON OPTIONS

Instruments can be configured with either of these options, but not both:

Analog Output Option

Data output at 40 Hz.

0-5 VDC or 4-20 mA with Software-definable ending sequences

Provided with 10' cable

RS-232 Serial Output Option

Select data sampling rate from 1, 2 or 5 Hz.

Provided with 10' cable to Interface with your receiving device

FEATURES OF ALL INSTRUMENTS

- Color graphic display:
- Large and easy to read, with adjustable backlighting.
- Shows Tension, Battery Charge Level, and Cable Size Selected.
- Includes user-definable tension set points.
- Store Function: Store and display up to five separate tension readings plus the minimum/maximum and average value of these stored readings.
- Data Statistics: Monitor your process by viewing count, average, minimum/maximum, and standard deviation values of your logged data.
- Selectable Tension Units: Choose to display tension in Lb, Kg or daN.
- Up to ten calibrations can be programmed into the instrument. (Password-protected to provide due diligence against unauthorized changes.)
- Adjustable LCD refresh rates allow for stable digital readings.
- Automatic shutoff after several minutes of non-use.
- All models are typically available from stock.
- All models are factory calibrated and ready for use.
- All calibration values are traceable to National Standards.
- Calibration certificate is included.
- Continuous operation while connected to power supply.
- Durable, lightweight carrying case with protective foam inserts included. (See Figure 2)
- Cable diameter gauge included, to easily and accurately measure cable size. (See Figure 3)



Figure 2: Carrying Case with Instrument, Calibration Certificate, charger, adapters, and operating Instructions.

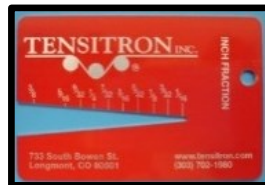

Figure 3: Cable Diameter Gauge



CHARGING INSTRUMENT BATTERIES

1. ⚠ Use only a Tensitron power supply to avoid damage to instrument.
2. Connect power supply cable to instrument. Plug the power supply into a power source with input voltages between 100 – 240 VAC.
3. A full charge of the battery assembly requires several hours of charging.
4. Battery pack assembly cannot be overcharged.
5. Instrument will remain on while connected to its power supply.
6. Battery charge level is indicated in the upper, right-hand corner of the display.

QUICK START INSTRUCTIONS

1. Power unit on by pressing ON button. Main display will indicate: Tension, Material, five stored tension readings and their average, and other information. (See Figure 4.)
2. Select a screen:
3. Move between screens by using the up (↑) and down (↓) buttons.
4. Make or enter a selection by pressing the Enter/Zero button.
5. Exit a setting by pressing the Escape (ESC) button.



Instrument Operation Panel

Main Display

Operation Buttons:
 Off / Escape
 On / Enter / Zero
 Arrow Up
 Arrow Down
 Store

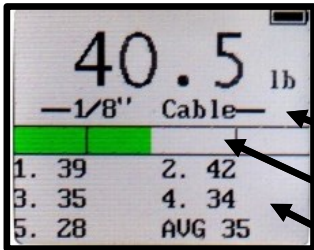

Main Display

Battery Charge Level

Selectable Units in Kg, daN, Lbs.

Select Cable Size – Instrument automatically adjusts calibration

Set Point Display

Store and Display up to 5 separate tension measurements and their Average.

Figure 4: Instrument Operation Panel and Display



1. Log Data:
 - a. Press the STORE button to store and display up to five separate tension readings along with the average of these values.
 - b. Clear the data displayed on the Main Screen by pressing and holding the STORE button, or power the instrument off.
 - c. For additional information on logging and viewing data, refer to Sec 6 Display Screens - Data Logging.
2. Read Tension: Variations in materials and cable diameters affect tension readings. It is essential to select the correct material and size before use, or tension values may be incorrect.
3. Select Tension Units:
 - a. Using the up or down arrows, scroll to TENSION UNITS, then press ENTER.
 - b. Next, select from: Kilograms, DecaNewtons, or LBS, and then press ENTER.
4. Select Material:
 - a. Using either the up or down arrows, scroll to SELECT MATERIAL, then press ENTER.
 - b. Next scroll through the cable descriptions until the correct cable size is highlighted, then press ENTER. Your main display will indicate the cable size selected. (See Figure 5)

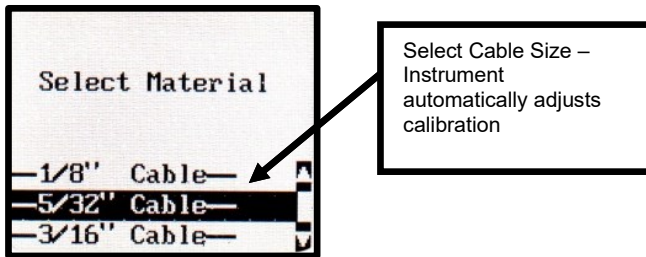

Figure 5: Select Material Screen

- c. If your specific material is not listed, add it to the menu by following the calibration instructions included at the end of these instructions. Or, send a 10' sample of your material/cable and the instrument to Tensitron and ask to have it added to the menu.
5. Zero Instrument: Hold the instrument in the attitude your reading will be taken before you engage it to the tensioned material/cable. Then, press ZERO.



ENGAGING INSTRUMENT ONTO CABLE

WARNING:

DO NOT OVER TORQUE THE ENGAGEMENT LEVER OR YOU WILL DAMAGE THE INSTRUMENT!

DO NOT EXCEED THE MAXIMUM TENSION RANGE OF THE INSTRUMENT OR DAMAGE WILL OCCUR.

- To engage the instrument on the cable, first rotate the engagement lever away from the instrument, raising the outer cable contact guides. Next, position your cable beneath the outer cable contact guides and above the center contact point. (See Figure 6)
- Once the cable is in place, squeeze the engagement lever shut until it locks into position parallel with the instrument handle. **Note: If it takes a lot of force to close the lever, STOP!, something is binding or the cable is too large in diameter. Closing the lever in this situation will damage the instrument.**
- Note the tension reading on the display. (See Figure 7)



Note the routing of the Cable.

Ready the instrument to accept cable by rotating engagement lever away from handle.

Figure 6: Instrument ready to engage



Note the routing of the Cable.

Once cable is properly routed, gently squeeze the engagement lever back toward the handle until it locks into the engaged position, parallel to the instrument handle.
Don't over torque!

Figure 7: Instrument engaged onto cable



SETUP SCREEN

LCD Refresh Rate

To either speed up or slow down the instrument's LCD refresh rates:

- Scroll to SETUP and press ENTER.
- Scroll to LCD REFRESH RATE and press ENTER.
- Select your preference: 1, 2 or 5 Hz and press ENTER. Note: This feature is unrelated to Data Averaging

Data Averaging

Note: This feature is primarily used in processes where the material to be checked is constantly moving, such as coil winding, and textiles, and likely does not apply to use on Aircraft cables.

Custom Names

Custom calibrations, listed as Custom 0 – 9, can be renamed so your material appears as a selection on the Main Display. To rename a Custom Calibration:

- Scroll to SETUP and press ENTER.
- Scroll to CUSTOM NAMES and press ENTER.
- Scroll to the description to rename and press ENTER.
- Input your custom name by using the up and down arrows to select each number, letter, or character, followed each time by ENTER.
- Continue pressing ENTER until all spaces in the description have values, including blank spaces.
- Once your new name has been entered you will automatically be returned to the SETUP screen.

Re-Calibrate Tension

See description at the end of this booklet.

ONLY PERFORM THIS IF YOU ARE A QUALIFIED CALIBRATION HOUSE USING NIST-CERTIFIED CALIBRATION WEIGHTS. NOT USED FOR CHECKING ACCURACY. TO CHECK ACCURACY, REFER TO SEC. 7: CHECK ACCURACY.

Audio

To turn the Beep ON or OFF:

- Scroll to SETUP and press ENTER.
- Scroll to AUDIO and press ENTER.
- Select ON or OFF and press ENTER.



Backlight

To adjust the visual intensity of the LCD screen.

- Scroll to SETUP and press ENTER.
- Scroll to BACKLIGHT and press ENTER
- Select Low, Medium or Full intensity and press ENTER.

Set-Point Menu

This feature displays tension as a colored bar on the main display. The colored bar advances as tension increases, and retracts as tension decreases. You can define a safe operating tension range. For tension measurements within this range, the bar is green. Below the range, the bar is amber. Above the range, the bar is red.

To adjust the Set Point Menu:

- Scroll to SETUP and press ENTER.
- Scroll to SETPOINT MENU and press ENTER.
- Follow and enter the prompts to turn this feature on or off, or to edit your high and low values. (See Figure 8)

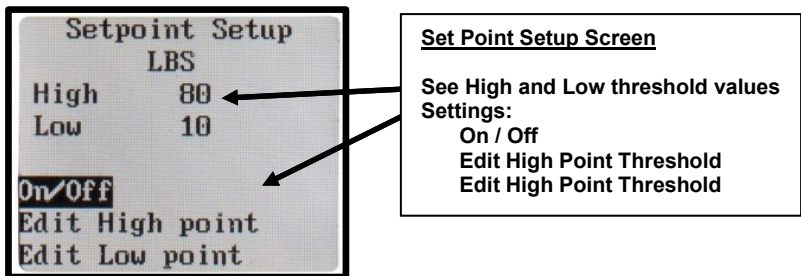

Figure 8: Setpoint Setup

Version

Press this button to determine what Model the instrument is set at in the firmware as well as to see what level of firmware is downloaded to the Instrument.

DATA LOGGING SCREEN

Each time the instrument's STORE button is pressed, a log of that cable tension will be stored into memory for later review.

View Data Stats

This feature allows the operator to view the basic statistics of the logged data (Count, Average, Minimum/Maximum, and Standard Deviation).

**View Data Log**

When data is logged to the instrument memory, that data and the statistics of that data log (Count, Average, Minimum/Maximum, and Standard Deviation) can be seen under the Data Logging / View Data Stats screen. To view this logged data:

- Scroll to DATA LOGGING and press ENTER.
- Scroll to VIEW DATA LOG and press ENTER.

Clear Single Point Log

To clear stored data, scroll to CLEAR SINGLE PT LOG, press ENTER, and follow the prompts.

TENSION UNITS SCREEN

To change the unit of measure in which tension readings are logged:

- Scroll to Tension Units and press ENTER.
- Use the Up and Down arrows to select Kilograms, DecaNewtons or Pounds and press ENTER.

SELECT MATERIAL SCREEN

Press ENTER while this display is shown to show the available options for the material types. Use the up or down arrow to scroll to the option you want and press ENTER to select it.



GENERAL CALIBRATION PRECAUTIONS

1. To verify the accuracy of your instrument, check the tension on a sample length of cable by suspending known weights from the opposite end.
2. When performing this test, use a micrometer to measure your cable diameter and ensure it is dimensionally within tolerances of Mil Spec #MIL-DTL-83420, and not out of round.

CABLE DIMENSIONS

Standard Aircraft Cables CWT Aircraft Cables

1/16" = .0625"	5-CWT = .076"
3/32" = .0938"	10-CWT = .106"
1/8" = .1250"	15-CWT = .141"
5/32" = .1562"	20-CWT = .155"
3/16" = .1875"	25-CWT = .170"
7/32" = .2188	
1/4" = .2500	

3. Only use free-hanging weights which are traceable to National Standards on correctly-sized cables. (See Figure 9.)
4. Never use any tensioning device that attempts to convert rotational torque values into tension loads, as these types of systems are highly inaccurate. Also, any load cell system must be routinely checked for accuracy using traceable weights as these types of systems are also highly inaccurate and generally do not meet the minimum repeatable accuracy standards required by ISO-17025.
5. NEVER SIMULATE TENSION LOADS ON THESE INSTRUMENTS BY USING A CALIBRATION BAR!

CHECK ACCURACY

1. Confirm that the size cable you're working with is the same size selected in your ACX's display.
2. Before engaging the ACX instrument onto the cable, zero the instrument by holding it in the same attitude you'll be taking the readings and press the "Enter" or "Zero" button. This will eliminate any small tare effects.
3. Take readings along the cable. **FOR BEST RESULTS ALWAYS TAKE SEVERAL READINGS OF THE CABLE TENSION BY DISENGAGING AND THEN RE-ENGAGING THE INSTRUMENT ONTO THE CABLE.**



4. Verify that the tension value is correct within the accuracy specification for your instrument:

Accuracy Specification

Model	2% full-scale accuracy:
ACX-100-1	+/- 2 lb.
ACX-250-1	+/- 5 lb.
ACX-500-1	+/- 10 lb.

For example, if you are using an ACX-250-1, and suspended weight is 40.0 lb. your instrument should indicate 40.0 lb. +/- 5.0 lb. once properly engaged to the cable.

This procedure confirms the instrument’s accuracy, and it is now ready for use.

CALIBRATE INSTRUMENT

***IMPORTANT: THIS FEATURE SHOULD ONLY BE USED BY A CALIBRATION FACILITY USING CERTIFIED AND TRACEABLE DEAD WEIGHTS. DO NOT USE THIS FEATURE FOR A SIMPLE ACCURACY CHECK.**

If you want to verify or check the accuracy of a cable go to: “Check Accuracy” in Section 7: Advanced Operation.

For proper calibration, the Tension Meter must be returned to Tensitron. For more information, contact service@tensitron.com.

TENSITRON®



733 S. Bowen Street
Longmont, CO 80501
USA

Phone: (303) 702-1980

E-mail: sales@tensitron.com

Web Site: www.tensitron.com

